



Design and Performance Study of Cost-Effective Smart Servo-Controlled Voltage Stabilizer

Prathamjeet Singh^a, Karthik Sharma^b, Divyansh Singh^c, Ujjwal Vaish^d, Dr. Ajay Kumar Maurya^e

^{a,b,c,d} Scholar, Department of Electrical Engineering, KIPM College of Engineering and Technology, U.P., India

^e Head of Department, Department of Electrical Engineering, KIPM College of Engineering and Technology, U.P., India

vishenprathamjeet33@gmail.com , kartiksharma@997083gmail.com , divyansh731@gmail.com ,

ujjwalvaish2004@gmail.com

KEYWORD

Servo-controlled stabilizer, Variac 0-270V, Microcontroller based actuation, Cost-efficiency, AC voltage, Closed-loop logic

ABSTRACT

The actual focus of this project to design a cost-efficient and approachably affordable **Smart Servo Controlled Automatic Voltage Stabilizer (SSCAVS)** which control the fluctuation of incoming input voltage and provide the constant voltage to the electrical equipment so they can work effective and efficiently. In India, there are several spots where the electrical supply is not stable because of which sometimes the voltage gets too high and sometimes it went too low. This fluctuation of voltage can cause severe effect to sensitive and expensive devices like computer, medical machines, motors as well as the daily used home appliances like fans, refrigerator, televisions, coolers, etc. In preference to avoid the damages to the electrical bodies we need a reliable voltage stabilizer. Our stabilizer continuously monitors the input voltage and automatically regulates the output voltage using a servomotor-based control mechanism. It conducts both high voltage as well as low voltage cut off protection, so whenever the voltage crosses its operating parameters, the supply which is connected to the load is disconnected to prevent the damage. This stabilizer works smoothly with different samples of loads like Inductive, Resistive, Capacitive, weather the voltage is in balanced or unbalanced conditions. This projects aim is to provide a low-cost, simple and user-friendly stabilizers so that people in rural and urban areas both can purchase and use it easily. This stabilizer maintains a stable output voltage even when the input varies between 170 volts to 270 volts. This gives the stabilizer enough potential to be reliable and long-life. This stabilizer is easy to use in every household, industries and offices. Overall, this stabilizer improves the power quality and useful in avoiding the problem of voltage fluctuation.

1. Introduction

Voltage fluctuation is one of the common and regularly occurring problem in residential, micro, small and macro industries subject to electric field. In countries with developing infrastructure, the quality of power which supplied to the consumers changes at regular interval due to several reasons that are intangible. This occurs because of overhead lines, long distance power distribution or even sometimes happen due to bad weather. This fluctuation can be light, slightly drop or highly raised output. Even if these issues are for the short time but still their repeated impact can harm the sensitive devices, lab equipment or even the daily used home appliances [1]. In today's era, most of the electrical devices relied on stable input voltage in order to function appropriately. Various household's devices like Semiconductor based, microcontroller based, motor based, etc. all depend on a precise voltage level.

When devices are introduced to undervoltage, they derive excessive current resulting to which devices suffer overheating and lifespan decrease, reference to which, overvoltage leads to breakage of insulation, stressed winding, failures of equipment. Conventional households' voltage stabilizer basically performs on relay-based switching

Corresponding Author: Prathamjeet Singh, Scholar, Department of Electrical Engineering, KIPM College of Engineering and Technology, U.P., India

Email: vishenprathamjeet33@gmail.com

systems. The voltage regulation on these devices is done by the variac by switching taps via electromechanical relays. Due to being inexpensive this approach is simple, but it is subjected to various limitations, corrections take place in micro phases rather than at once. Inherently stabilizers that work on relay-based modules may not achieve precise control over the output voltage and even occurs small disturbance during switching [2]. To solve these issues, various scholars subjected to electrical field began to explore continuous stabilizing techniques, where the output voltage is controlled through smoothly controlled component —usually known as Dimmer stat or Auto transformer/Variac or Servo driven voltage stabilizers. Variac gives a smooth voltage correction, provides the good waveform quality and operates very smoothly without jerks. Although, industrial based servo-driven stabilizers are expensive by nature due to the presence of heavy motors, control loop technique and sensor modules within their bodies. Leading with the excitement, our team got curious to design a cost-effective and affordable servo-based stabilizer with component available nearby [3]. The present work clarifies the curiosity through the development of a Smart Servo-Controlled Automatic Voltage Stabilizer, built using an Arduino Uno, MG996R high-torque servo motor, LM358(ZMPT101B)-based analog voltage sensor, and an Autotransformer 0-270V/2A. Traditional relay-based stabilizers are widely used at the low-cost segment market but they provide limited precision and relatively having slow response time. At the other side, high end servo stabilizers, offers excellent accuracy but still remains too expensive for many consumers. A Smart Servo based Stabilizer have traits such as Accuracy due to which it maintains the output within 1–2% very close of the desired voltage, Speed allows to answer extremely fast to any often fluctuations. This stabilizer is designed to work in a smooth manner without sudden voltage steps, avoiding mechanical and switching noise and also avoid the chattering that is common in the conventional stabilizer. All the components used are of the low cost and easily available components in the local markets, which makes the system affordable and practical for common users. Built in safety features ensured by protecting the connected equipment from extreme voltage disturbance, reducing the risk of faults [4].

The Arduino works in a closed loop system where it continuously monitors the input voltage and compares it with the desired level. If there is any difference it instructs to the servomotor to adjust the variac according to the voltage need. This coordination between mechanical parts, electrical circuits and software control results in the low-cost effective voltage stabilizers. Another advantage of a microcontroller-based design is we can easily program to perform several tasks. This system supports the features such as data logging, IoT monitoring, LCD, PID tuning or mobile control. The system works as a closed-loop controller. The sensor senses the outgoing current voltage. The Arduino compares this value to the preset voltage (e.g., 220V). If the output is different from the expected value, the Arduino changes the servo angle to rotate the variac knob according to the need. This creates a continuously happening self-correcting mechanism. Many research papers previously discussed microcontroller-based stabilizers, but the majority one uses the old system solid-state switches, transformer tap-switching, or SCR-based control [5]. These systems have some of the common problems like harmonic distortion because if electronic switching, not getting the proper protection from transients, complexity increases of the SCR/triac and also become costly due to isolated gate drivers. Servo-based autotransformer gives the better performance, but they are not used too much in the academic projects because people thinks that it is costly and complex to use. However, the emergence of low-cost MG996R servos and Arduino boards becomes practical and easy to build. There is also limited literature on Low-cost voltage sensing using LM358 V3 modules for AC feedback, performance validation of servo-based stabilizers under fluctuating input, analysis of stability, overshoot, and dynamic response using hobby-grade hardware and Cost comparison between relay stabilizers and microcontroller-based servo stabilizers [6]. This research addresses these gaps.

The proposed stabilizer offers several advantages like Continuous Voltage Control which means that the voltage doesn't jump suddenly like other relay stabilizers. The Servomotor rotates the variac smoothly which gives better and more accurate control. Arduino can adjust the servo within milliseconds; this helps in reduce the sudden voltage fluctuations. Programmable Logic are being used due to which reference voltage, limits of servo, speed and protection features can be easily changed and improved by software. The variac is highly efficient and having low power loss due to which system become more energy efficient. The stabilizer is being cost-effective, as all components (Variac, Servo, Arduino, LM358 V3 module, Buck CA-2596 module) are affordable and easily available [7]. It is safe for the sensitive electronics devices as there is no switching noise, no harmonic distortions, and no annoying relay clicking sound. The main idea is to use the stabilizer as a feedback control system, where the output voltage is sensed, converted into an analog voltage, and then given to the microcontroller. The microcontroller calculates that how much the voltage has changed and sends the correction signal to the actuator [8].

Mathematical Representation,

if:

V_{ref} = desired output (for e.g.- 230V)

V_{out} = measured output via meter

therefore, $e = V_{ref} - V_{out}$

The controller changes the servo angle such that output moves toward V_{ref} .

Our work is proof of some significant features which is reflected via this research paper:

A cost-effective servo stabilizer can be easily built using simple affordable and available parts.

Closed-loop controlled system improves the systems performance.

Variac-based stabilization is suitable for both laboratory and household use.

Arduino-based control is flexible for educational and industrial purposes.

Sensor-based automation makes the system automatic, user-friendly and expandable in the future with major future scopes.

The project showcases how modern embedded systems can revolutionize electrical designs through cost savings, improved performance, and logic programming.

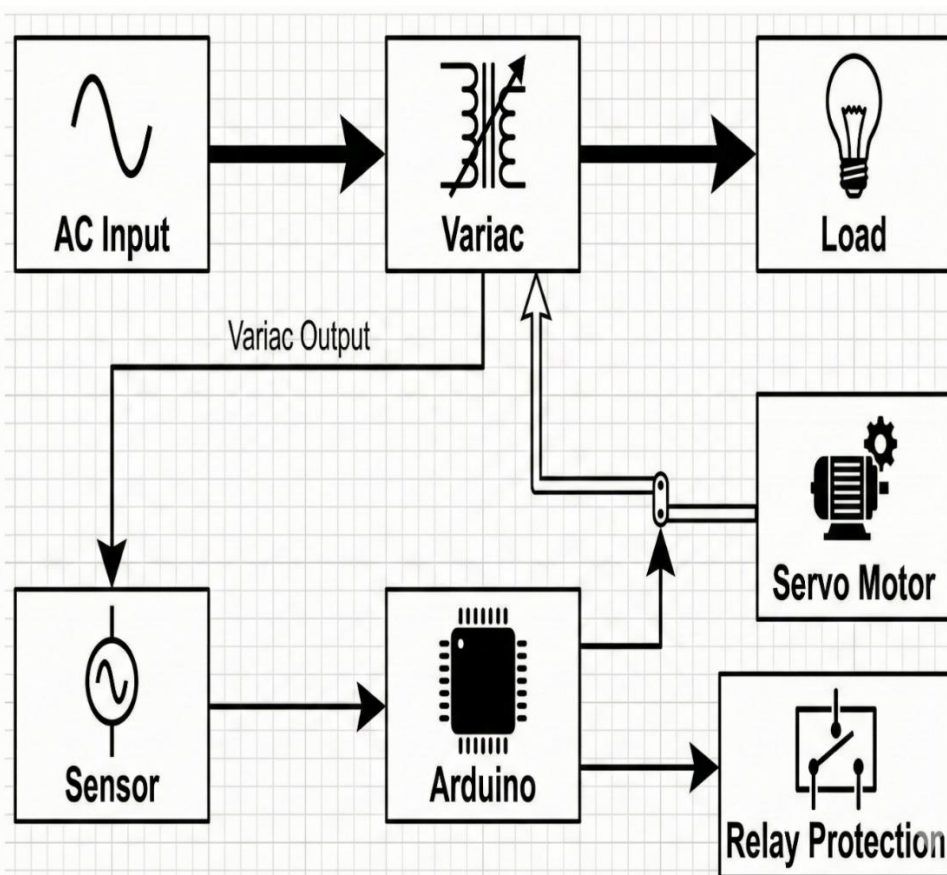

Figure 1: Block diagram of Smart Servo-Controlled Automatic Voltage Stabilizer

2. Methodology

The methodology basically ensures the actual prototype's design of hardware, automated mechanism, feedback system controlled by sensor and microcontroller, and obviously programming that supports the cost effectiveness and potential of the complete project which actually is automatically driven and servo controlled. The methodological order of the project follows a closed-loop strategy that in a continuous order sense the output voltage and then corrects it if needed that too in real time affect.

The integration of the hardware design initially took place via a 0-270V/2A variac which regulates primarily because of its potential to provide control over voltage that is stepless and also shows intangible waveform distortion. The variac is supported by MG996R servo motor as it rotates the variac's viper arm roller with a torque of 10-12 Kg with digital confrontation from its supportive in the loop.

The LM358C(ZMPT101B) is responsible for the voltage feedback which actually supports the servo motor's rotational mechanism by sensing the output AC voltage and converting it to a digital analog signal with is compatible to the Arduino's ADC. The design poses safety measures via electrical fusing, isolation and sufficient grounding through the components.

The prototype is then followed by software interaction. The Arduino indulges with the voltage samples that is collects at several intervals, interacts with the errors between the computed output and referenced target for e.g. - 230V and then adjusts the servo angle with a proportional standard. The code is also embedded with enough safety measures to avoid the over rotatory action of variac and disconnect the output through relay pitch during high deviation of the voltage [6]. The methodological aspects ensure the smooth continuous regulation of voltage along with being inexpensive, compatible, modular. The attempt conjugates electromechanical design, control engineering principles, embedded system to build an ambitious stabilizer prototype.

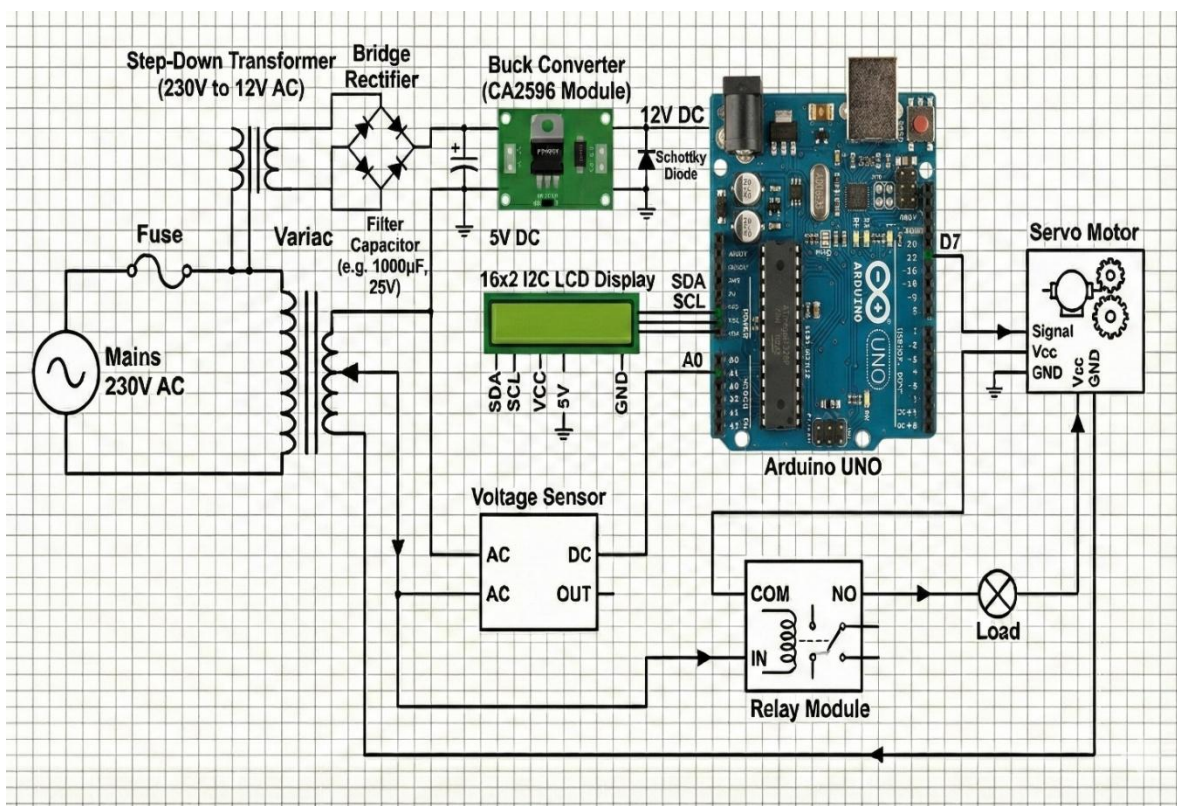

Figure 2: Schematic Diagram of Smart Servo-Controlled Automatic Voltage Stabilizer.

3. Software Interface

In the smart-servo controlled automatic voltage stabilizer, the software interaction plays a core and focused role about intelligence in the prototype. The software allows real time sensing, data actuation, logical protection and decision making. The complete programming was enacted by Arduino Uno microcontroller using the Arduino IDE software that endeavours a spontaneous platform for embedded algorithmic enhancement.

The data acquisition and signal processing is done via Arduino as it collects the voltage samples via voltage sensor ZMPT101B using 10-bit Analog to Digital Convertor. The IDE software contains a calibration routine checkup for mapping of the ADC readings that are correspondent to AC voltage values as the sensor circulates scaled and analog values as output. The program engages with several samples in order to apply digitalized greasy filter to avoid the noise as much as possible, also this results in minimizing jitters, enhancing stability, accuracy, responsive control and precisions.

The software does consist of a closed-loop controlled algorithm that asserts responsible impact as it continuously compares the quantified values with the set referential value for e.g.- 230V. The difference between values is responsible for the formation of error signal processed by proportional correction method. The response of the servo against the deviation of output waveform depends on the proportional gains. The major software components involved are: Arduino IDE, Servo.h, LiquidCrystal.I2C library for actuation, control algorithm code and serial monitor tools (mainly at 115200 baud). Last but not least, the software in this project provides essential potential for stability, sensing, accuracy and surveillance.

Closed-Loop Control Algorithm for Servo-Controlled Voltage Stabilizer

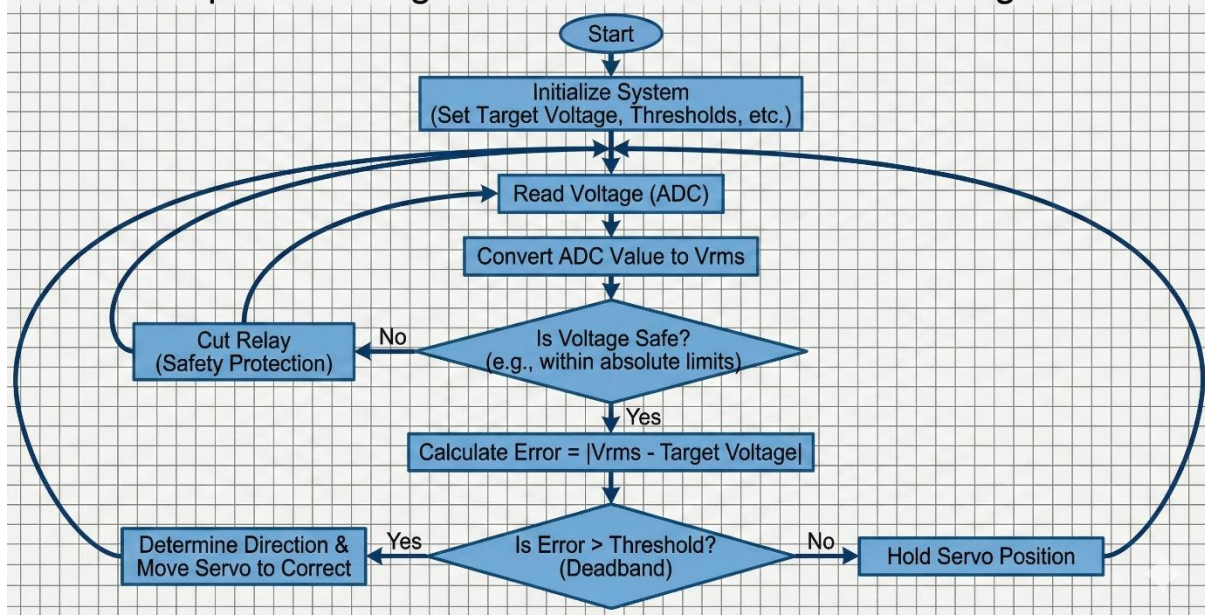

Figure 3: Flow Chart of Closed Loop Controlled System.

4. Arithmetic and Thermodynamics Approach

In this project, the principles of electromagnetic induction run the variac which does consist single phase winding and a metallic wiper arm roller which is subject to the several number of effective turns. So, with subject to transformer law:

$$V \propto N$$

Where: V= Voltage output

N= Number of effective turns

The number of engaged turns get changed simultaneously as it depends on the movement of the wiper arm roller that is moves by the servo across the coil. The increase in radius of contact increases the number of turns resulting in raised output voltage and effectively decreasing the radius does the vice versa.

The variac runs continuously without switching the taps resulting to a continuous smooth voltage output proportionally to the wiper angle for ideal regulation.

The ideal core of the variac is subject to the Faraday's Law:

$$V = -N \cdot d\Phi/dt$$

Where, Φ is the constant flux and by controlling the N, we attain the controlled output.

Now, discussing about the arithmetic model of closed-loop control, let:

$$V_{ref} = \text{desired output voltage}$$

$$V_{out} = \text{calculated output voltage}$$

$$e(t) = V_{ref} - V_{out}$$

now, moving forward, the controller performs a proportional correction method:

$$\theta(t) = \theta(t-1) + K_p \cdot e(t)$$

where K_p = proportional gain.

The Stability condition for a closed loop is as such:

$$0 < K_p < K_{p,crit}$$

Mapping between the ADC value and the Actual Voltage is done via an analog signal that is output from LM358 V3 that is proportional to the AC RMS voltage after rectification and filtration.

Let,

$$V_s = \text{sensor output}$$

$$V_{ADC} = 1023 V_s / 5$$

The real AC voltage is mapped as:

$$V_{AC} = \alpha \cdot V_{ADC} + \beta$$

Where,

α = scaling factor found from calibration

β = Offset value.

Analyzing the response of the loop when the input varies:

Sensor acts to gain V_{out} value

Error $e(t)$ tends to be non-zero

The variac gets adjusted as controller moves servo

The position of wiper arm roller due to its mechanism changes the output voltage.

The loop repeats until the error is observed as zero.

Let's acknowledge the negative feedback loop for ensuring stability:

$$e(t) = 0 \text{ and } t = \infty$$

Now, the experiment typically measures the settling time:

$$T_s = 300 - 400 \text{ms}$$

5. Results and Discussion

Before the final result, this project, due to its sensitivity had to go through various sub results after being calibrated on various factors and conditions. Factors are as such:

5.1. Components testing and experimentation

Here, in order to build a reliable prototype, initially, we must have core components with assured health and proper functionality and test them against their potential, response to what, it was decided to drive the 0-270V/2A variac against the MG996R servo motor, same as the microcontroller Arduino Uno was tested by running a closed loop, LM358 V3 was calibrated by the output monitoring, lastly the input voltage was varied intentionally from a range of 160V to 250V resulting to what every stage was tackled by the prototype and its components.

5.2. Settling and Responsive behavior

When there's any sudden disturbance, a stabilizers' potential of being responsive to the disturbance via its critical performance metric strategy is responsible for it. While the test was run, the servo stabilizers' system showed certain characteristics:

Initial time reaction: 87ms – 122ms

Complete correction time: 250ms-400ms

Overshoot: < 1.95-2.89V

Steady state ripple: Minimal (<1V)

This shows how smooth the servo moved without any oscillation due to perfect tuning with the proportional gain K_p and also the systems well-damped behavior was observed in the first loop.

5.3. Stability

Dealing with the major problem of Servo Stabilizing in today's era is to tackle its back-and-forth movement, so in this project factors like **servo rate limiting, filtered ADC readings and deadbands of 1V** ensures about the system approach to attain stability by avoiding oscillation.

5.4. Calibrating for Load Impacts

During the testing, sets of resistive loads were tested ranging from 150-200W which resulted with following discussions:

- Even at a low Torque, the servo utilized its full potential which was sufficient.
- The load was driven by the variac at a smooth rate.
- Under the load condition the sensors' reading remained stable.

Analyzing the complete discussion, we obtain:

- Even low-cost and easily affordable components can also achieve high performance.
- Continuous stabilization takes over relay-based step system as the output remains very close to the offset value.
- We can gain mechanical stability in complete form only with a strong mechanical linkage.
- Once the calibration of LM358 V3 is done, since then, it provides consistent feedback.
- Last but not least, the servo-stabilizer resulted as a compact, intelligent and most importantly reliable version of its commercial one, only at a fraction of its cost.

6. Conclusion

Via the completion of this project that is 'The design and performance study of a cost-effective smart servo-controlled automatic voltage stabilizer' it can be assured that the with some very affordable, accessible, reliable and high market grade components a high-precise and highly reliable voltage regulation system can be designed that actually do shows the properties of intellectually controlled, mechanically and accurately stabilized sensing. The relay-based stabilizers had a few drawbacks like slow response, stepwise correction, mechanical noise, slow and lengthy response so this stabilizer is built to exhibit the custom drawbacks of relay stabilizers.

It is observed that the several experimental results show how the servo maintains continuous flow of output voltage within a range of $\pm 2\%$ of the reference value across the wide-ranging input voltage i.e. 170V to 250V.

Also on the other hand, the stabilizer expresses immense safety features such as over-voltage and under-voltage shutdown using a relay in order to ensure that the connected loads remain protected against the adverse conditions.

Reference

- [1]. M. Loogesh, C.R. Sridhar, B. Tamizharasan, *Smart Servo Controlled Automatic Voltage Stabilizer*, Bannari Amman Institute of Technology, Anna University, May 2022.
- [2]. Rahul Govind Jadhav, Neha Naresh Varunkar, Vasant Suresh Tirodkar, Gauri Subhash Daddikar, Mestry Sachin Shankar, *Design and Implementation of Servo Voltage Stabilizer for Commercial and Industrial Application*, IJEDR, Vol. 8, Issue 1, 2020.
- [3]. Hnin Hnin Aye, *Design and Construction of Control System for Automatic Voltage Stabilizer*, International Journal of Trend in Scientific Research and Development (IJTSRD), Vol. 3, Issue 1, Nov–Dec 2018.
- [4]. G. Naveen Kumar, *Design of a Low-Cost Servo Controlled Voltage Stabilizer*, International Journal of Research in Engineering & Technology, Vol. 4, Issue 3, Mar 2016, pp. 43–46.
- [5]. Mohammad Shah Alamgir, Sumit Dev, *Design and Implementation of an Automatic Voltage Regulator with Great Precision and Proper Hysteresis*, International Journal of Advance Science and Technology, Vol. 75, 2015.
- [6]. S. Suresh, R. Prakash, *Microcontroller-Based Servo Voltage Stabilizer*, International Journal of Engineering Research & Technology (IJERT), Vol. 3, Issue 9, 2014.
- [7]. P. Kumar, R. Singh, *Design and Simulation of Automatic Voltage Stabilizer Using MATLAB/Simulink*, International Journal of Electrical Engineering, Vol. 2, Issue 3, 2013.
- [8]. M. R. Islam, A. K. M. S. Alam, *Performance Analysis of Servo Motor Controlled Voltage Stabilizer*, International Journal of Electrical Power Systems, Vol. 1, Issue 2, 2012.